

NexStar-3

EXTERNAL 3.5" HARD DRIVE ENCLOSURE
USB 2.0/FIREWIRE INTERFACE



Model: NST-360UF-BK

Specifications:

Interface: FIREWIRE & USB 2.0
Dimension: 206 X 123 X 33 mm
Supports Window 98SE / ME / 2000 / XP
Mac OS 8.6 & Above

Package Includes:

Driver Disc
User Manual
3.5" HDD Enclosure
Power Adaptor
Power Cable
FIREWIRE cable
USB Cable
Vertical Stand
Screws

Platforms

Window 98SE / ME / 2000 / XP
Mac OS 8.6 & Above

System Requirements

Intel Pentium II 350 MHz-compatible
or Mac G3 processor & greater
Microsoft Windows 98SE/ME/2000/XP
or Mac OS 8.6 & greater
USB or FIREWIRE-equipped system
For USB 2.0 speeds, the system must
support USB 2.0 specifications
CD Rom drive (if drivers are needed)

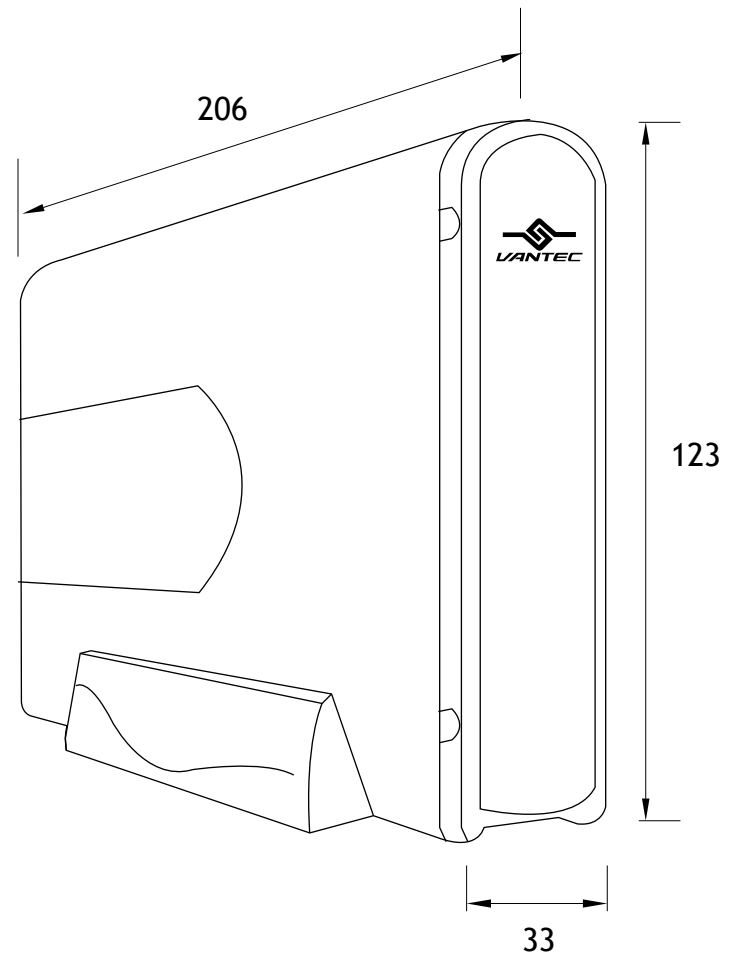

43951 Boscell Road
Fremont, CA 94538
Tel: 510-668-0368
Fax: 510-668-0367

www.vantecusa.com

Copyright © 2006 Vantec Thermal Technologies. All Rights Reserved.
All registered trademarks belong to their respective companies.