

NexStar

EXTERNAL 2.5" HARD DRIVE ENCLOSURE

Model: NST-250U2

Dimension:

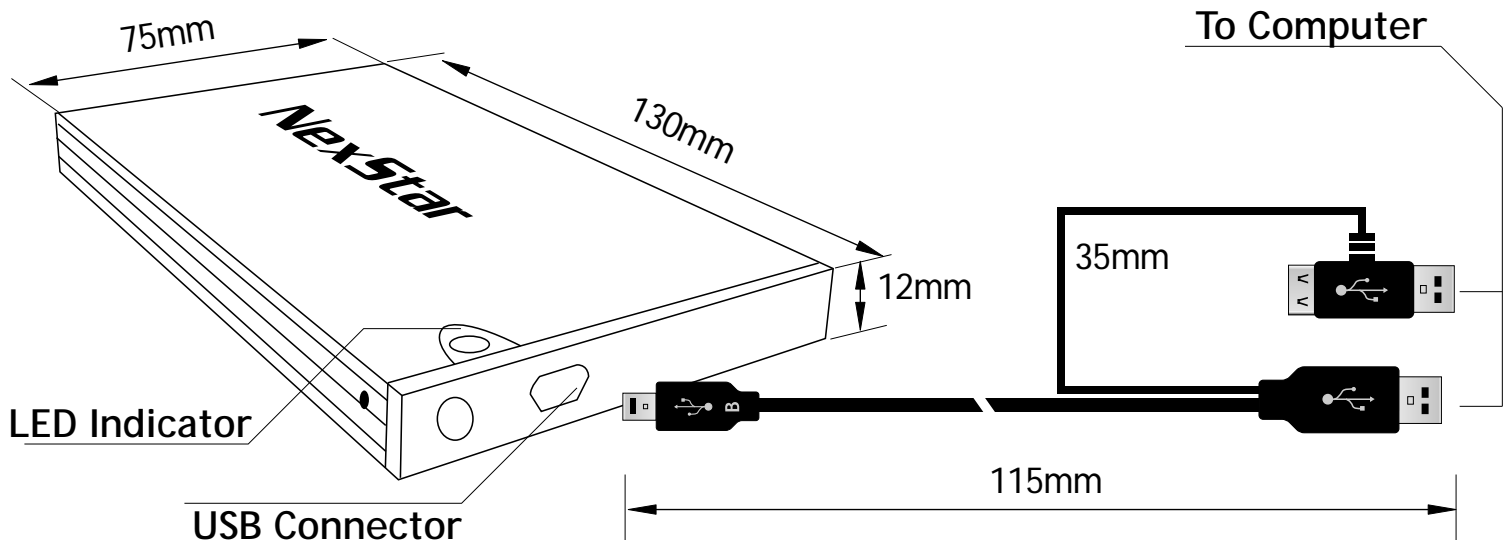

Product Specifications:

Interface: IDE to USB 2.0
Dimension: 130 x 75 x 12mm
Weight: 65g
Material: Aluminum Alloy
Supports Window 98SE / ME / 2000 / XP /
Mac OS 8.6 & Above

Package Includes:

Enclosure
Installation CD
USB Cable
User Manual
Protective Sleeve

43951 Boscell Road
Fremont, CA 94538
Tel: 510-668-0368
Fax: 510-668-0367

www.vantecusa.com